

STEEL TANKS

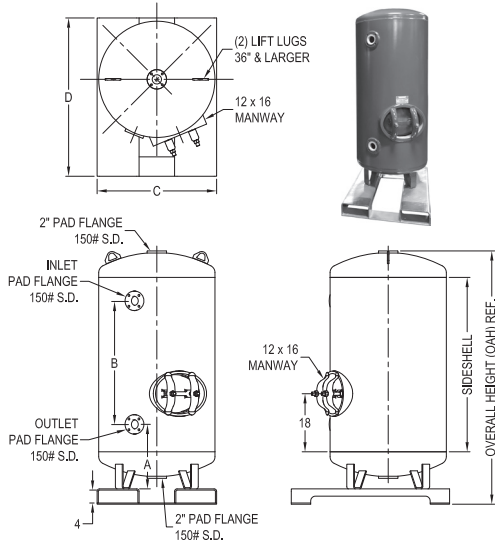

MOBILE STEEL TANKS



SWT's Mobile Steel Tanks have two 2 inch pad flange top and bottom openings; 2 or 3 inch pad flange inlet and outlet openings located on the side wall of the tank; a 12 x 16 inch manway; and a bolted-on galvanized fork tube base. All tanks larger than 36 inches in diameter come standard with lift lugs. SWT's steel tanks are durable, rustproofed, and built to last. Made in USA.

These pressure vessels are available in non-code and ASME code construction; and with polyethylene (PE) or Plasite 4110 vinyl ester (VE) lining.

- Meets all requirements for both FDA and US Department of Agriculture
- Single drilled pad flanges
- Polyethylene (PE) lining is repairable with heat in the field
- Max. operating pressure: 100 psi
- Max. operating temperature: Polyethylene 100°F; Plasite 4110 Vinyl Ester 140°F
- Standardized equipment means faster shipping
- Custom designs available
- Optional sight glass available

Part Number	Lining Material	Tank Size Inches	Inlet and Outlet	Volume		Dimensions				
				Total Volume Cu.Ft.	Head * Volume Cu.Ft.	Overall Height Inches	Dim A Inches	Dim B Inches	Dim C Inches	Dim D Inches
Non-Code Tanks										
UQ-2460MPE-2(?)	Polyethylene	24 x 60	2" PAD	17	0.8	77	14	46.50	28	37
UQ-2460MVE-2(?)	Vinyl Ester	24 x 60	2" PAD	17	0.8	77	14	46.50	28	37
UQ-3057MPE-2(?)	Polyethylene	30 x 57	2" PAD	26	1.9	79	18	41.25	31	43
UQ-3057MVE-2(?)	Vinyl Ester	30 x 57	2" PAD	26	1.9	79	18	41.25	31	43
UQ-3654MPE-2(?)	Polyethylene	36 x 54	2" PAD	37	3.0	79	20	38.25	37	49
UQ-3654MVE-2(?)	Vinyl Ester	36 x 54	2" PAD	37	3.0	79	20	38.25	37	49
UQ-4252MPE-3(?)	Polyethylene	42 x 52	3" PAD	50	4.6	79	21	36.25	43	55
UQ-4252MVE-3(?)	Vinyl Ester	42 x 52	3" PAD	50	4.6	79	21	36.25	43	55
UQ-4848MPE-3(?)	Polyethylene	48 x 48	3" PAD	63	7.0	79	23	32.25	49	61
UQ-4848MVE-3(?)	Vinyl Ester	48 x 48	3" PAD	63	7.0	79	23	32.25	49	61
ASME Code Tanks										
UQ-2460MPE-2(?) - ASME	Polyethylene	24 x 60	2" PAD	—	—	81	15.7	46.50	28	37
UQ-2460MVE-2(?) - ASME	Vinyl Ester	24 x 60	2" PAD	—	—	81	15.7	46.50	28	37
UQ-3057MPE-2(?) - ASME	Polyethylene	30 x 57	2" PAD	—	—	84	20.2	41.25	31	43
UQ-3057MVE-2(?) - ASME	Vinyl Ester	30 x 57	2" PAD	—	—	84	20.2	41.25	31	43
UQ-3654MPE-2(?) - ASME	Polyethylene	36 x 54	2" PAD	—	—	85	22.7	38.25	37	49
UQ-3654MVE-2(?) - ASME	Vinyl Ester	36 x 54	2" PAD	—	—	85	22.7	38.25	37	49
UQ-4252MPE-3(?) - ASME	Polyethylene	42 x 52	3" PAD	—	—	86	24.2	36.25	43	55
UQ-4252MVE-3(?) - ASME	Vinyl Ester	42 x 52	3" PAD	—	—	86	24.2	36.25	43	55
UQ-4848MPE-3(?) - ASME	Polyethylene	48 x 48	3" PAD	—	—	85	25.8	32.25	49	61
UQ-4848MVE-3(?) - ASME	Vinyl Ester	48 x 48	3" PAD	—	—	85	25.8	32.25	49	61

(?) Substitute B for safety blue epoxy finish coat; or W for white epoxy finish coat. Example: UQ-2460MPE-2B is 24 x 60 blue colored tank with PE lining.

* Head Volume includes the straight flange of the head.